



GREENSPOKE

BIKE PARKING SOLUTIONS

1-844-888-9999
www.gogreenspoke.com

Model: RP-V5 Freestanding Repair Post

Complete with Secured Tools, High-Pressure Pump and Bike Hanger

Finish / Material: Powder Coated, Single Colour (TBD), over High Strength Steel Body

- General Specifications, Sheet 1 of 2 -

Rev.: 08Sep23

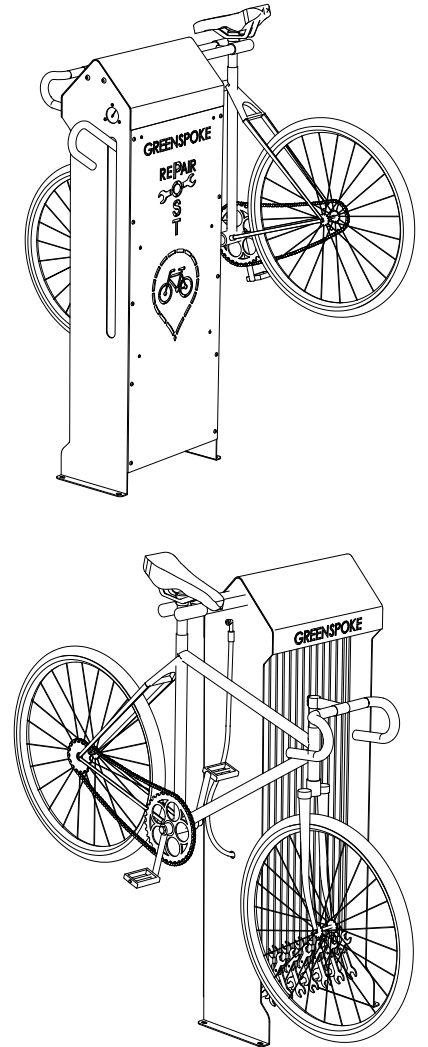
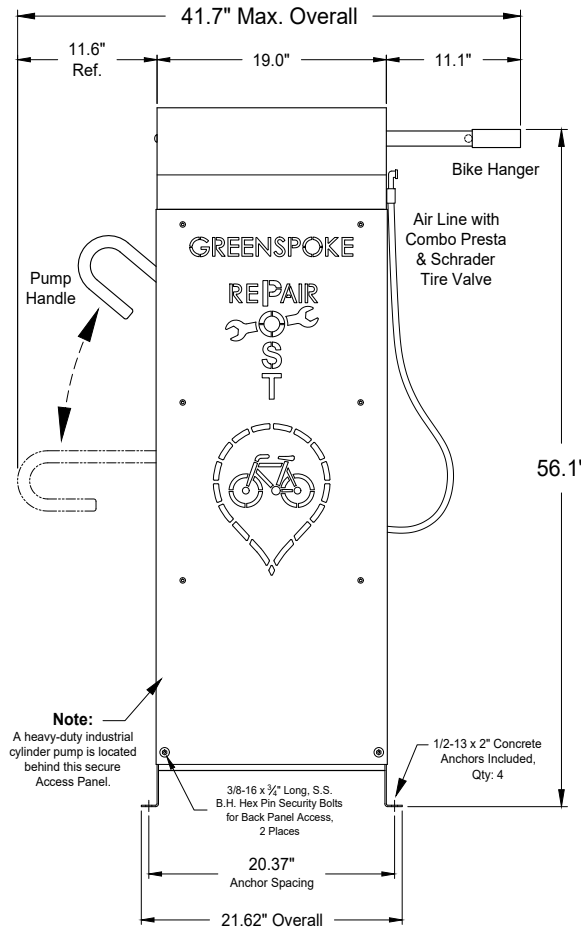
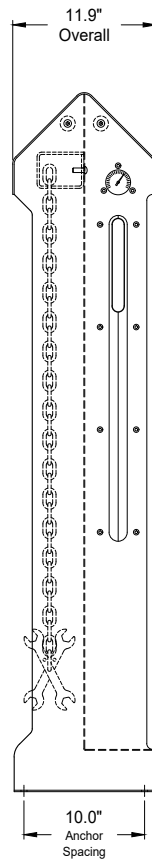
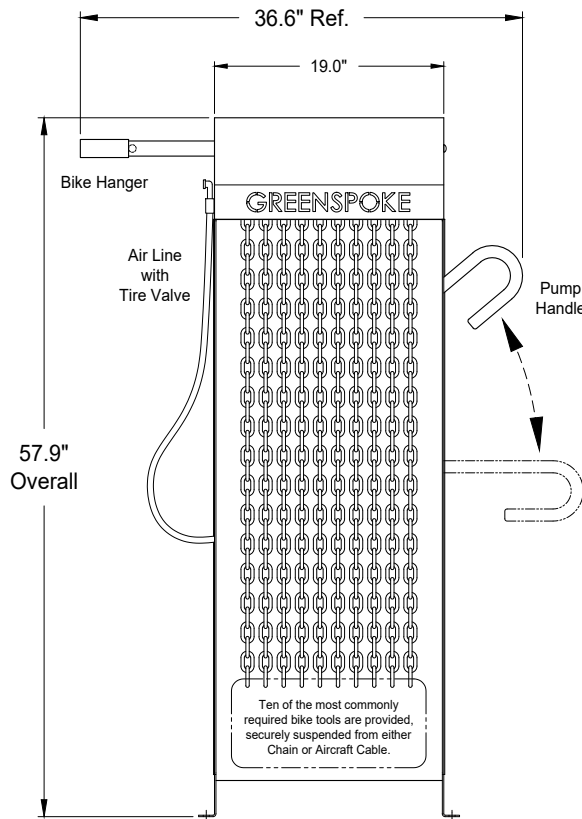

Repair Tools:

- 1) Philips Screwdriver
- 2) Flat Head Screwdriver
- 3) Allen Wrench Combo Set: 2.5, 3, 4, 5, 6, and 8 mm
- 4) Open-end, flat wrenches for pedals, hubs, and bearings: 13, 14, 15 & 16 mm (Qty: 2)
- 5) Open-end, flat wrench for head set: 30, 32, 36, & 40 mm
- 6) Adjustable Wrench, 6" long, for axle nuts, etc.
- 7) Tire Levers (Qty: 2)

Tool Tether / Lanyard Options:

- 1) 36" Long, High Security Chain, Cut Proof 1/4" Diameter Hardened Steel, Transport Grade T-7 Type, with Corrosion Resistant Coating.
- 2) 36" Long, Plastic Coated, High Strength Stainless Steel, Braided Aircraft Cable with Swivel and Clevis: Provides superior flexibility and dexterity for tool use.

Primary Housing Materials:

- 11 Ga. Steel Main Housing.
- 14 Ga. Steel Access Panels.
- 7 Ga. Steel Tool Channel.
- 1.32" O.D. x .125" Wall HSS Tube Bike Hanger.
- Stainless Steel Hardware.

Approximate Total Weight: 165 lbs (75 kg)

Finish:

Polyester Powder over Zinc Rich Primer.

Dimensions shown are in inches.

Greenspoke maintains a policy of continuous product improvement.

As a result, some details may change without notice.